

Modell der Serie MY 1100 DSB/Bauart NOHAB

88632

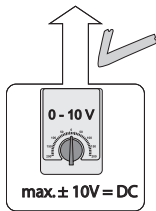

max. $\pm 10V = DC$

67011

67020 + 67030

67201

67271

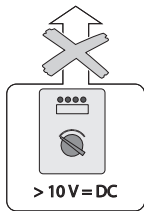

$> 10V = DC$

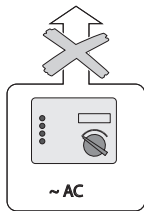

$\sim AC$

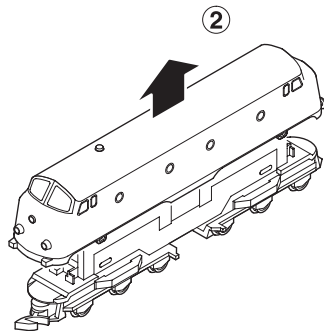
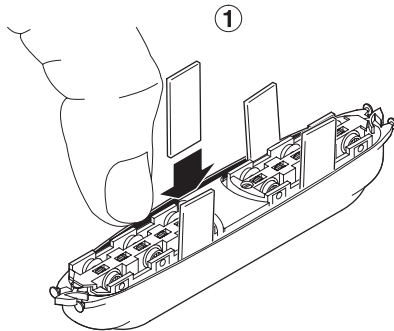

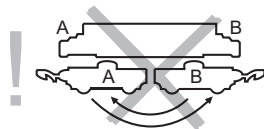
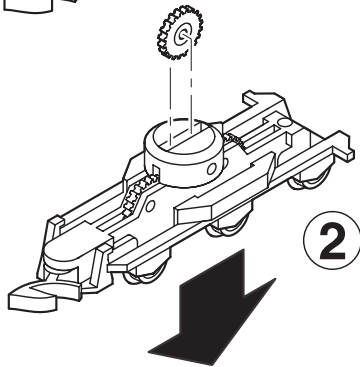
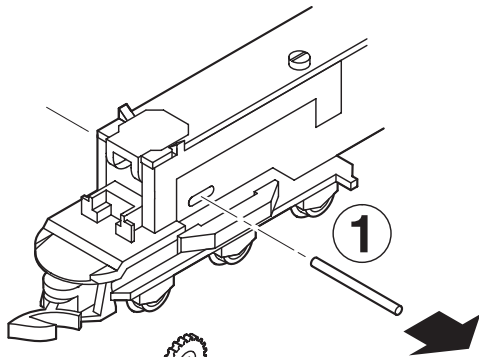

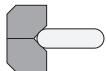

8953

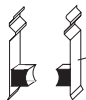

89891

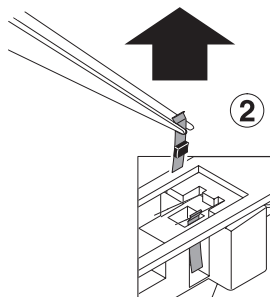
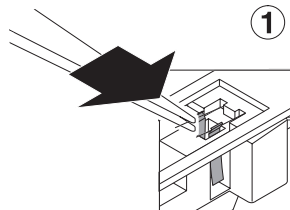
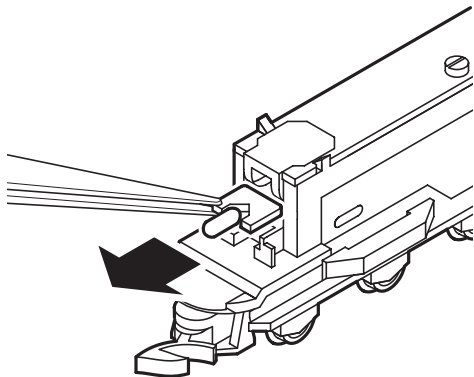

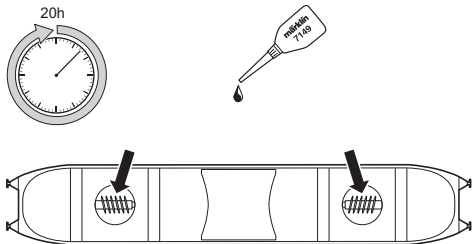

- Nur sparsam ölen (max. 1 Tropfen). Zuviel Öl führt häufig zum Verschmieren der Kollektoren und damit zur Beschädigung des Ankers.
- Oil sparingly (max. 1 drop). Too much oil frequently causes the commutator to become dirty and thereby leads to damage to the armature.

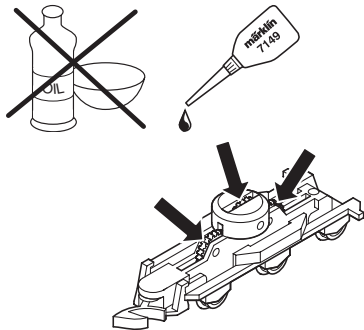

- Lubrifi ez en très petite quantité (1 goutte max.). Trop d'huile entraîne souvent l'encrassement du collecteur et à des dommages à l'induit.
- Na het aanbrengen van de oliedruppel op het motorlager het anker rondraaien. Aansluitend met een droge doek de overvloedige olie verwijderen.

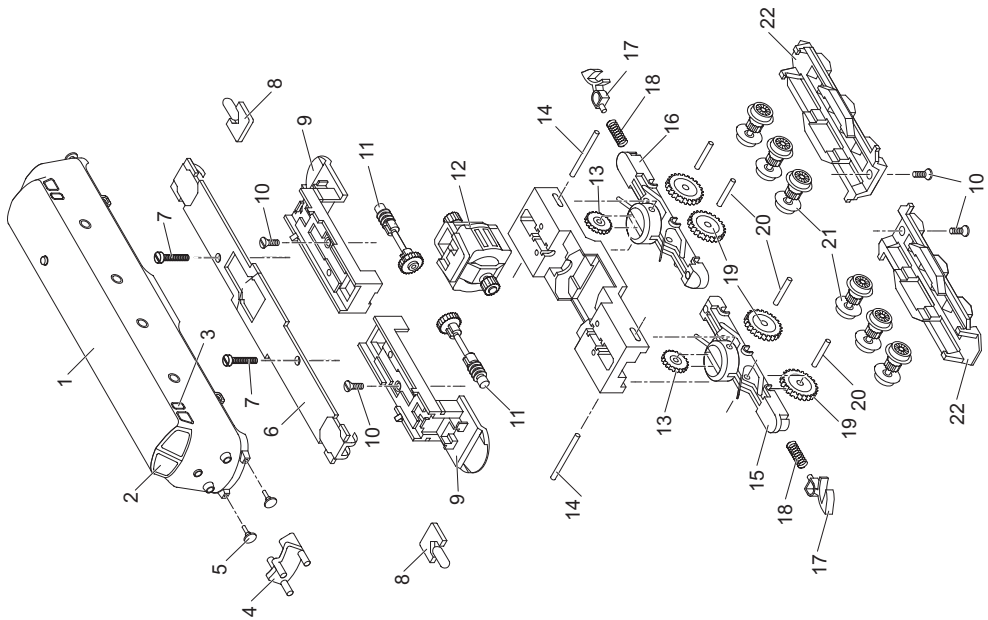

1	Aufbau komplett	140 086
2	Stirnfenster	231 492
3	Seitenfenster	231 489
4	Lichtkörper	231 491
5	Puffer	761 790
6	Leiterplatte	231 771
7	Zylinderschraube	785 190
8	Beleuchtungseinheit	8 953
9	Isolierung	223 332
10	Senkschraube	785 550
11	Antriebswelle	262 310
12	Motor	211 903
13	Zahnrad	262 190
14	Achse	260 720
15	Getriebegehäuse vorne	262 460
16	Getriebegehäuse hinten	262 450
17	Kupplungshaken	704 200
18	Druckfeder	765 680
19	Zahnrad	260 730
20	Achse	262 240
21	Treibradsatz	216 476
22	Drehgestellrahmen	262 280

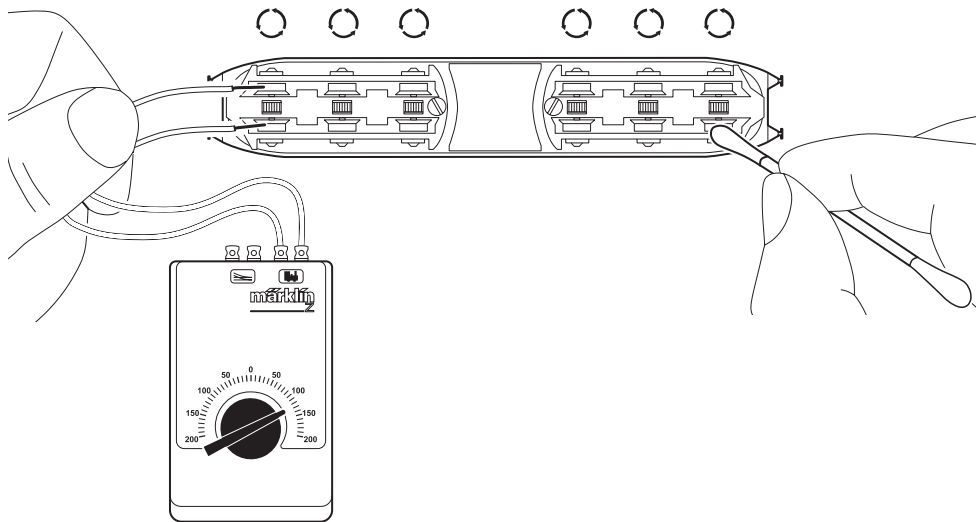

Gebr. Märklin & Cie. GmbH
Postfach 860
D-73008 Göppingen
www.maerklin.com

140091/0808/SmSk
Änderungen vorbehalten
© by Gebr. Märklin & Cie. GmbH